

Neuer Schweizer Vertriebspartner für **ROTO motor**

Beratung und Verkauf

**Modellsport
Huggler**

3073 Gümligen | +41 79 586 17 45
info@modellsport-huggler.ch | modellsport-huggler.ch



Roto 170 FS

Roto 130 FSI in line



Manual ROTO 35 FS



Czech Republic

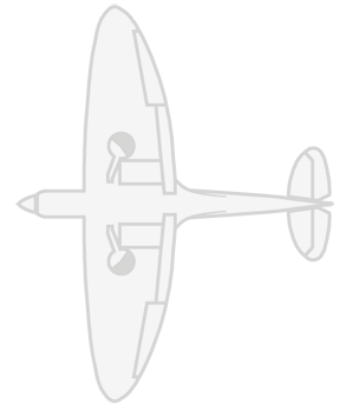

Modellsport
Huggler

Congratulation for choosing the four stroke engine ROTO produced in Czech Republic. For more information about our engines please visit our web sites www.rotomotor.cz

Assembly of the engine

Please follow the instructions carefully.

First check that all the listed parts are in the box.

Contents of the box:

1. Engine
2. Carburetor
3. Carburetor gasket
4. Exhaust
5. Engine mount
6. Hoses
7. Screws

1. Mounting of the carburetor

Please locate the carburetor + gasket and attach it with two 4 mm Allan head bolts. (included) (picture No.1)

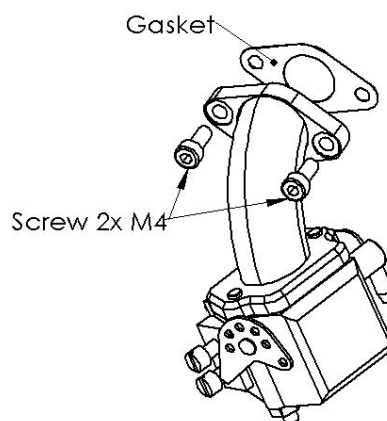

2. Attaching the oil overflow hose

Connect the hose to the engine body.

This hose should be connected to an overflow nipple on the engine and routs the spent oil out of the engine body to best suitable place in your model.

There is no restriction to the length of hose. (The hose must not be pinched).

3. The exhaust

The exhaust pipe should be attached with out the use of the gasket and care must be taken when tightening the nut.

DO NOT OWERTIGHTEN! As this will permanently damage the head of the engine!

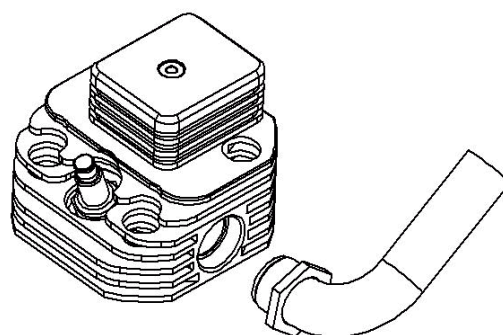

4. The engine mount

The engine comes with aluminum engine mount and attaches to the engine with 4pc of 5mm Allan head bolts.

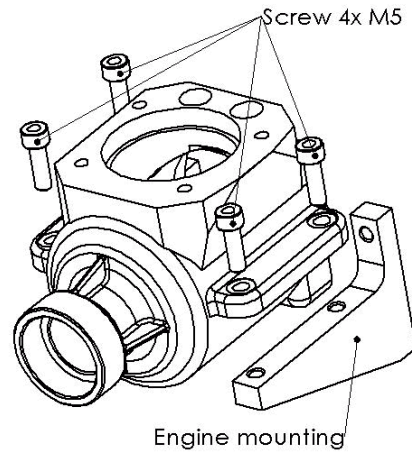

Fuel: Factory recommended fuel for the ROTO 35 FS is a standard 95 octane gasoline mixed with quality 2-stroke oil (Motul 800) at the 1:40 ratio (2,5%).

Gas L	Oil ml
1	25
2	50
3	75
4	100
5	125
6	150

The carburetor adjustment

The carburetor is factory adjusted and should NOT need an adjustment before a first flight.

Should you wish to adjust the carburetor after the Run-in period and fine tune it to the prop of your choice, please use the following procedure.

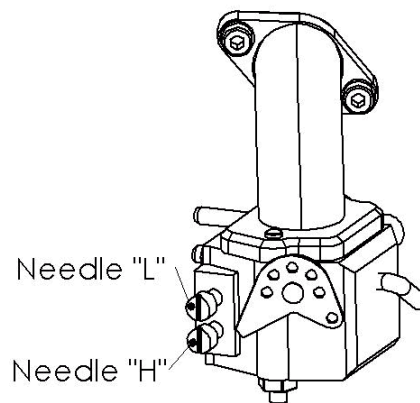

Set the High needle (H) for the highest RPM. After you are satisfied with High-end, adjust the Low (L) needle for smooth transition between High and Low range with out any hesitation.

Your engine should run 6,000 RPM with 20/10 prop \pm 5% at 1,000 Ft elevation.

The valves adjustment

After the run-in period (2 hours) the valves must be adjusted. Remove the valve cover bolt and the valve cover. Turn prop until the magnet and sensor are lined up. Loosen the nuts and adjust the gap for 0.1 mm or 0.004” on both suction and exhaust valves.

Re-tighten and re-install the valve cover.

This procedure should be repeated after 8 hours again. After that the valves should not need any more adjustment unless:

- there was a crash of the model
- a prop size or a pitch changed
- the engine was disassembled

Propeller installation

The propeller must be attached with 4pc of 4mm bolts (included).

It is necessary to check and re-tighten the propeller several times, specially when using a new wood propeller (as new one will compress the wood in first running of the engine). Loose bolts will result in sheering of the bolts and CAUSING SERIOUS DAMAGE TO THE PERSON(s) or to your model!!!

Engine maintenance

This four-stroke engine includes a magnetic particle trap. It is located under the carburetor in the engine block and is necessary every 10 hours of operation unscrewed and removed eventual dirt.

Engine installation

It is necessary to provide enough fresh air to the intake of the carburetor. (In case of lack of air, the engine may exhibit poor performance and it may fluctuate at the maximum speed.)

It is necessary to ensure sufficient cooling of the cylinder heads and of the cylinders by sufficient supply of fresh air from the propeller and/or from the ambient environment.

ROTO electronic ignition instructions

The ROTO ignition is a microprocessor controlled ignition with automatic spark timing advance made for 4stroke gas fuelled ROTO engines.

Weight: 100 grams, (3,5 Oz.)

Supply Voltage: 4-9V

Input current: 50 mA – 500 mA

Advance range: up to 38 degrees advance

The ignition is equipped with a novel feature, A IED indicator mounted on wire lead external to the ignition. The LED will blink when the ignition is first turn on

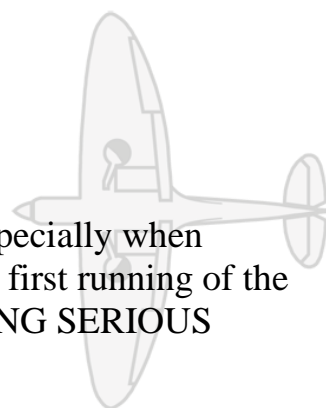

indicating that the ignition is functional. After the engine is started the LED will blink at the RPM rate. Stopping the engine (with the choke or throttle) and keeping the ignition turned on will extinguish and after this short interval the LED will blink at a rate of ½ of the maximum RPM attained during the recent ignition operation. This data may be read from the LED with an optical tachometer (you may need to shield the tachometer sensor from other lights).

This RPM info will help you gather information on how your engine/prop combination is performing in the air!

Installation of the ignition

The ignition needs to be located and mounted in such a manner that it is isolated from extreme temperature and shock. The power input connector is JR/Hitec compatible. The spark plug lead should be secured so it does not rub against engine or airframe components.

The hall sensor mounts on the crankcase of the engines. There are NO user adjustments required or needed.

When the magnet on the hub of the engines passes the hall sensor (and the ignition is turned on) a high voltage pulse is supplied to the spark plug. BE CAREFUL! The spark pulse is in excess of 20 thousand volts!

Test your model for proper radio operation before flying, turn on the radio system (transmitter antenna fully collapsed), start the engine (while being held by a second person) and walk away 100 feet while moving the sticks and observing the control surfaces. Any random movement of the surfaces indicates a problem with the radio system which must be investigated...do not fly the model.

The ignition has two years warranty. Do not attempt to service the ignition module. There are no user serviceable parts. Return it for repair or replacement. The warranty does not cover crash damage or abuse.

SAFETY!!!

PLEASE READ THE INSTRUCTIONS CAREFULLY.

ALLWAYS USE GLOVES AND SAFETY GLASSES WHEN STARTING THE ENGINE!

The engine warranty is 40 months.

-7-

WARANTY REGISTRATION CARD

Product name:	
Type:	
Product serial number:	
Date of purchase:	
Signature:	
Dealer's name, address:	
Stamp:	

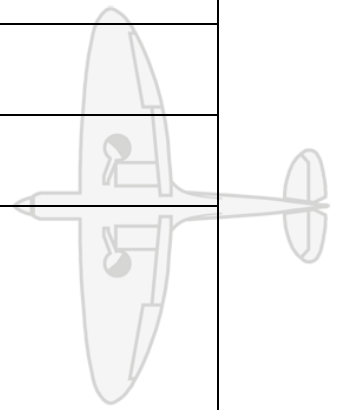

**Modellsport
Huggler**

ROTO 35 FS

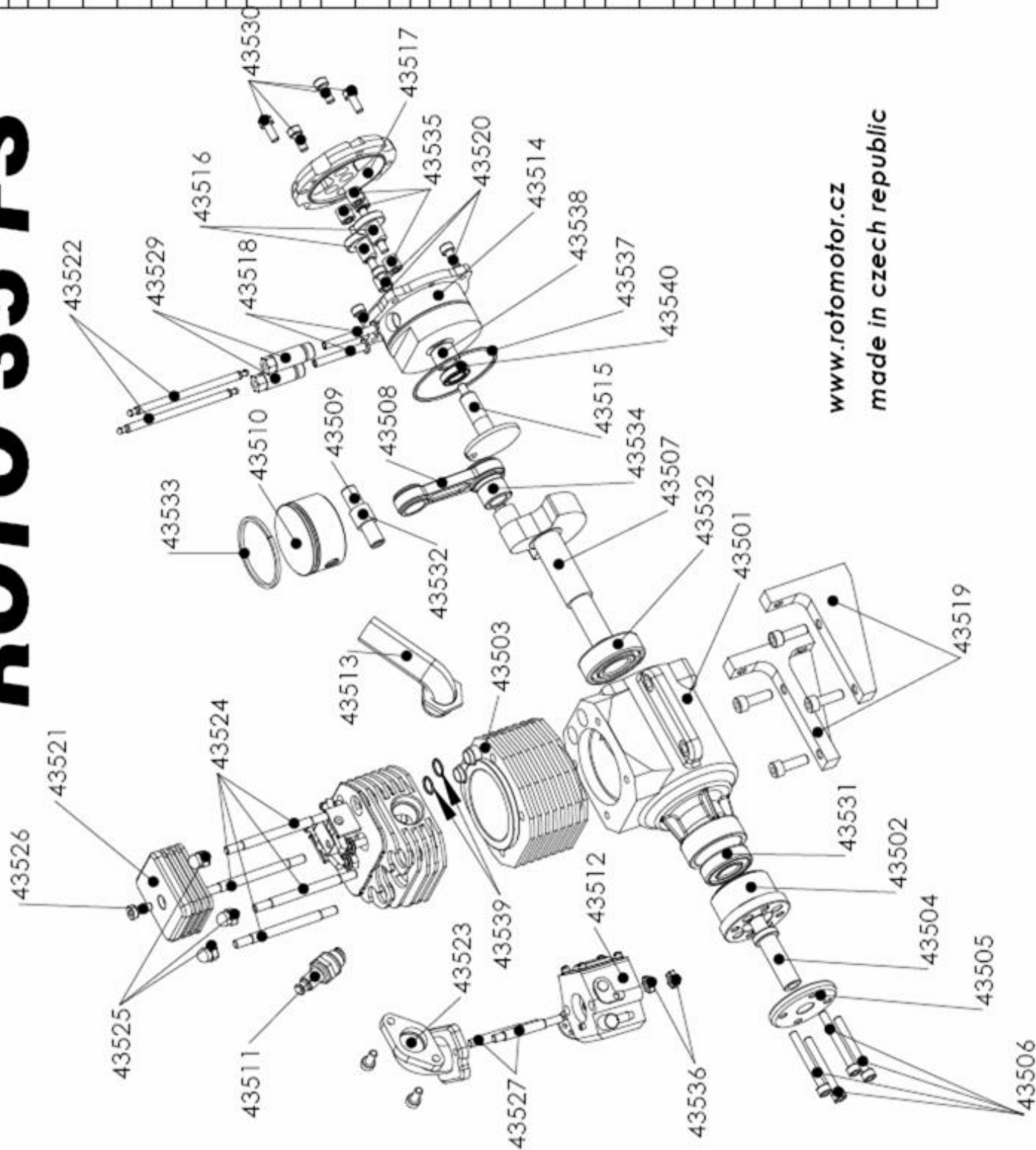

ITEM NO.	PART NUMBER	DESCRIPTION	QTY.
1	Karier	Engine block (př)	1
2	Unášeč vrtule	Hub	1
3	Válec	Cylinder	1
4	Čep vrtule	Propeller center bolt	1
5	Podložka vrtule	Propeller mount, plate	1
6	Šroub M4 x 35	Propeller screw M4x35	4
7	Křivkovička	Crank shaft	1
8	Ojnice	Connecting rod	1
9	Přísní čep	Wrist pin	1
10	Píst	Piston	1
11	SVĚTLA INK M10x1	Spark plug INK M10x1	1
12	Karburetor	Karburetor	1
13	Výfuk	Exhaust	1
14	Zadní víko	Back engine cover	1
15	Pastorek	Pinion	1
16	Vřačka	Cam	2
17	Vřetko	Cover	1
18	Zdvíhací	Tappet	2
19	Lože	Engine mount	2
20	Šroub M4x10	Screw M 4x10	6
21	Vřetko vřetovičky	Lever cover	1
22	Těžiška zdviháčka	Stick of tappet	2
23	Sání	Suction	1
24	Švorník volice	Cylinder bolt	4
25	Matice M5	Nut M5	4
26	Šroub M4x10 rábý	Screw M4x10 low	1
27	Švorník karburátoru	Carburetor bolt	2
29	Vodítko	Guide	2
30	Šroub M4x4	Screw M4x4	4
31	Ložisko 6001	Bearing 6001	1
32	Ložisko 6002	Bearing 6002	1
33	Přísní kroužek	Pinion ring	1
34	Ložisko HK 1210	Bearing HK 1210	1
35	Ložisko HK 0408	Bearing HK 0408	5
36	Matice M4	Nut M4	2
37	O kroužek 50	O ring 50	1
38	Ložisko HK 0910	Bearing HK 0910	1
39	O kroužek 10	O ring 10	2
40	Gufero	Gufero	1

www.rotomotor.cz

made in czech republic